

Genuine Accessories



Vehicle Model **MULTIPLE**

Model Year 2017-

Part No. B1F39 AU000

Language English

Rev. Date 8/10/2016

Accessory: **License Plate Frame**

Difficulty: **A**

Note: Difficulty stated above reflects the minimum level of expertise required to install the accessory:

- (A) Customer
- (B) Dealer Technician
- (C) Master Technician or Specialist

Instructional Symbols / Definitions

	Denotes warnings that may lead to serious physical injury or vehicle damage		Denotes quality processes to be checked prior to moving to the next step	Denotes personal protective equipment (PPEs) that may be required for a step. Examples of safety equipment icons noted below:	
	Denotes cautions to be taken to avoid physical injury or electronic component damage		Denotes specific tools that are necessary to complete a step		
	Denotes cautions to be taken to avoid vehicle and component damage	N O T E	Denotes important information to be reviewed during the step		
				Glasses	Gloves
				Mask	Hearing Protection

Basic Required Tools



**#2 Phillips
Screwdriver**

Part Weight (Gross)

0.65	lbs
0.29	kg

FMVSS 110 Compliance Information

All dealers must determine if the weight they have added in the form of all options or accessories, when added to the weight of all Port/Dealer installed options or accessories, exceeds the lesser of 1.5% of GVWR or 100 lbs. If the additional weight does exceed the lesser of the indicated thresholds, a "Load Carrying Capacity Reduced" label must be installed. A black, fine-point, indelible marker must be used to write by hand onto the label, the reduced carrying capacity in kilograms or pounds, which is the total weight of all added options and accessories.

Load Label Part Number: NP070 - 09003

Notes to the installer:

- 1 Read the entire Installation Instructions prior to beginning the installation of the part.
- 2 Make sure the vehicle is completely clean and dry in the area(s) the part is to be installed.
- 3 Ensure the vehicle is properly protected in the area(s) that the accessory is to be installed.
- 4 NEVER place tools on painted surfaces, seating surfaces, dash pad, console or floor carpet/mats.
- 5 Always wear appropriate personal protective equipment, including gloves, safety glasses, etc., when required.

Kit Overview

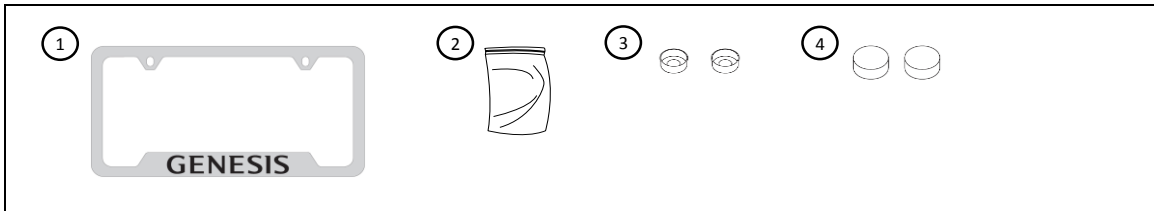



No.	Qty	Description
1	1	License Plate Frame
2	2	Snap Cap
3	2	Plastic Washer
4	1	Hardware Kit



Hardware Kit Contents

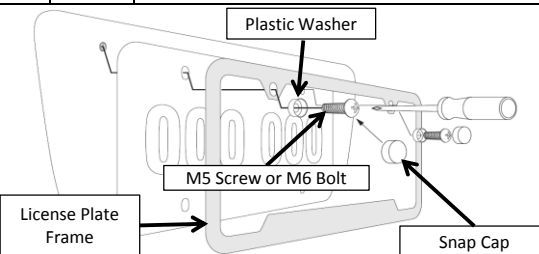

A		B	
2	M6 x 1.0 Bolt	2	M5 x 20mm Screw
Hardware Total			
4			

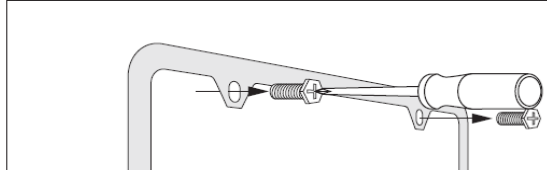

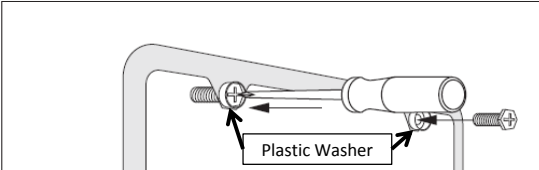
Genuine Accessories

1		
		
N O T E	Installation Overview	

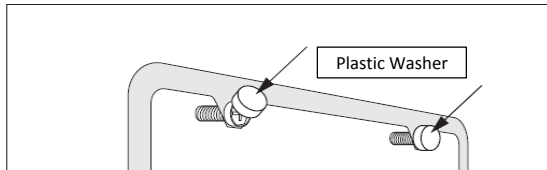
2		#2 Phillips Screwdriver
		
N O T E	<ol style="list-style-type: none"> 1. Remove 2 (two) existing bolts or screws from the license plate and frame (if equipped), and remove from vehicle. 2. Discard the bolts or screws. 	

3		#2 Phillips Screwdriver
		
N O T E	<ol style="list-style-type: none"> 1. Align the License Plate Frame holes over the license plate and vehicle attachment holes. 2. Depending on vehicle configuration, install one (1) M6 Bolt or one (1) M5 Screw through one (1) Plastic Washer and through the License Plate Frame, license plate, and into vehicle attachment holes as shown. 3. Tighten the M6 Bolt or M5 Screw securely. Do not overtighten. 4. Repeat notes 2 & 3 for the other side. 	
	Make sure the M6 Bolt or M5 Screw fits inside of the Plastic Washer.	

4		
		
N O T E	<ol style="list-style-type: none"> 1. At a slight angle, align one (1) Snap Cap over the Plastic Washer and push the Snap Cap until it snaps into place. 2. Repeat note 1 to install a Snap Cap on the other side. 	
	Make sure the Snap Cap is securely attached to the Plastic Washer.	

Visual Check	
	Item to be Checked
	Plastic Washer is properly installed onto M6 Bolt or M5 Screw.
	Snap Cap is securely attached.

	Result
	Plastic Washer installed properly.
	Securely attached.